



Little Flyers Platform Swing

Max Load: 220 lbs
Max Number of Users: 1
For Ages 5 - 12
Two Person Assembly

Parts Included:

- 1 piece Fabric Seat
- 4 pieces Tube Frame
- 2 pieces Rope with attached Screw Eye Hooks
- 8 pieces Washers
- 4 pieces Lock Nuts
- 1 piece Wrench

Page 1/4

Not Included:

- Socket Wrench (for convenience)
- Attachment Device and Support Structure

Hanging Installation:

- 1) It is extremely important to do a thorough study of where you plan to hang your swing. Review information provided in these instructions from the Consumer Product Safety Council regarding Protective Surfacing. The swing should NOT be installed over any sort of hard surface such as packed earth, gravel, concrete or asphalt within the Use Zone area. Install over level surface.
- 2) DO NOT hang swing near any sort of other swinging structures.
- 3) Make sure to hang swing a minimum of at least 12 feet away from any structures/objects including, but not limited to, garages, power lines, fences, house, branches, trees, structures used for hanging the swing, laundry lines etc. This is considered as the Use Zone for this Swing and its motions.
- 4) When selecting the height of the structure, make sure that it is comfortable for the user in a sitting position. The height of the structure will depend on the apparatus used for hanging. The bottom of the swing should be a minimum of 18 inches from the ground and no more than 24 inches.
- 5) The swing is hung by securing the two O-Rings on the rope to the attachment device on your support structure. The suspension points of these O-Rings should be at least 25 1/2" apart.
- 6) Make sure your attachment device and support structure are rated for more than 250 LBS of dynamic load.
- 7) One option for a support structure is a Cross Bar. Directly threading the Cross Bar through the O-Rings for hanging is NOT recommended as your Cross Bar needs to be narrow enough, and therefore it may sag or not be strong enough. Additional hardware will be required for a Cross Bar as the attachment device. Talk to the supplier/manufacturer of the Cross Bar to ensure that it is adequate for hanging your swing and inquire on additional hardware required in order to hang swing securely. A second option for hanging your swing is to use straps specifically designed for hanging swings. Kits are readily sold online and in store. They include components such as straps with attached heavy-duty carabiners. Make sure the kit purchased meets the load requirement. Talk to the supplier/manufacturer of the kits/straps to ensure that they are adequate for hanging your swing.

Care Instructions: Surface wash only with a clean, damp cloth. Do not immerse in water. No bleach.

Maintenance:

- Check all the fasteners immediately after the first use, and tighten again if necessary.
- Inspect the whole unit, including any attachment device and support structure, every week (or more frequently if under constant usage) for wear and tear or loosen fasteners. Check for rust, deterioration, corrosion and/or any sort of damage. Check the fabric and seams for tears, cuts and fraying. Immediately stop using the swing if any problems are found. Maintain the unit in safe working condition at all times.
- Check play area for any foreign objects. If necessary, refill protective surfacing materials.
- When disposing the swing, make sure to follow the regulations of your waste provider and disassemble to help prevent injury when discarded.

Assembly Instructions:

Page 2/4

Before You Start:

Make sure you have a comfortable and clean flat space with adequate area to work. Keep in mind that having a person assisting you is helpful. Check to make sure that all contents are accounted for. Keep young children out of the way as there will be small parts laying around.

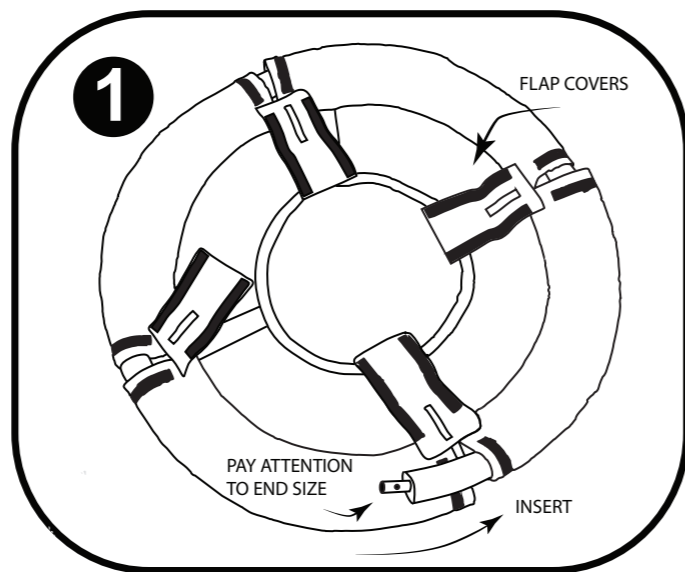

Lay Fabric Seat on the floor. Top side is where flap covers are attached. Locate the slots in the Fabric Seat; insert one Tube Frame per slot until all 4 Tubes Frame sections are inserted. Pay attention to the sizes of the ends during insertion.

One end of each Tube Frame section will be larger than the other end.

Since you will be inserting the smaller end of the tube into the larger end of an adjacent tube, make sure you orient the ends correctly.

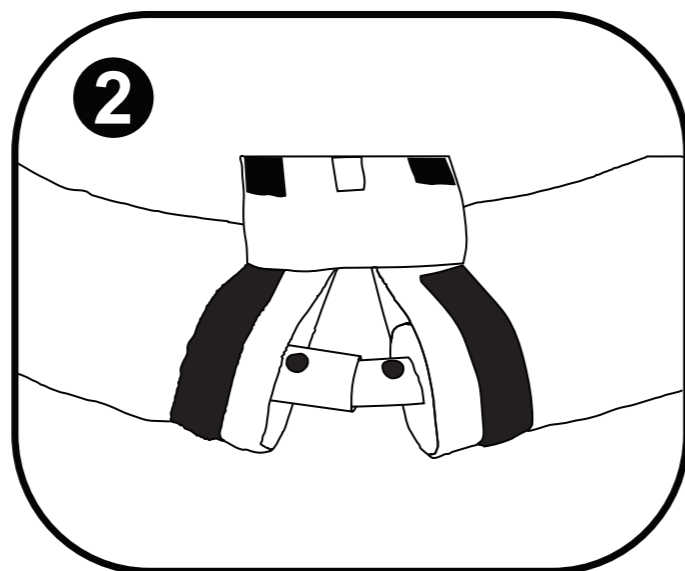

Using the drawing as reference, one by one, firmly connect the Tube Frames by inserting the small ends into the large ends. Watch for sharp edges and take care not to pinch fingers. Make sure the screw holes on the connected Tubes can be lined up properly. Tubes are covered by foam for safety reasons. You may have to pull back foam to find the screw holes on the tube.

Tip: To line up screw holes on tubes, it may be beneficial to wiggle while pushing the tubes together.

You may choose to line up the last screw hole when you are ready to insert the Screw Eye Hook in the next step.



Using the drawing as reference, position a washer at the top and bottom of the tube connection. Insert Screw Eye Hook through the flap opening and into screw hole through the washers. Tightly secure Screw Eye Hook using the Lock Nuts and Wrench.

Make sure Lock Nuts are tighten properly by catching the locking threads, but not over tightening to the point of damaging the nuts. Turn down the Flap and cover the joint. Repeat until all 4 Screw Eye Hooks are securely connected.

For the 4th and final tube connection, it is helpful to stand the swing on its side, with the 4th joint at the top and push downwards. This will help to line up the holes.

Safety Instructions:

- 1) For residential home use only.
- 2) ADULT SUPERVISION REQUIRED AT ALL TIMES. DO NOT leave child unattended while using this item.
- 3) Prior to each use, make sure potential users understand and follow all safety instructions.
- 4) Before each use, check all connections and ropes to avoid sudden breakage. Make sure ropes and any device used for hanging are in correct orientation, secure and tight at all times.
- 5) DO NOT allow users to wear any loose or baggy clothing, scarves, drawstrings, hats etc. Make sure users are properly attired.
- 6) Shoes must be worn at all times.
- 7) DO NOT put anything under the seat.
- 8) The swing is meant to be used while sitting. Do not jump or stand on swing. Do not jump off swing.
- 9) Make sure user is sitting with their weight in the center of the swing seat.
- 10) DO NOT allow the swinging of an empty seat.
- 11) Make sure children do not run, walk, play or be close to the swing when in use.
- 12) Do not twist ropes, this will weaken the ropes and create tearing.
- 13) Never swing higher than the pivot point (the point where the swing is attached to).
- 14) To safely get off the swing, make sure swing is at complete stop and continue holding onto the ropes until both feet are positioned on the ground.
- 15) Use the swing for its intended purpose only.
- 16) To extend the life of the swing, do not leave outdoors exposed to the elements (such as direct sunlight) for a long period of time. It is best to store the unit indoors when not in use. UV exposure and extreme temperatures will weaken and compromise the strength of the swing.
- 17) Surfaces exposed to direct sunlight and heat may reach high temperatures that could cause burns. Adult supervisor should check for hot surfaces before letting children play.
- 18) DO NOT modify the swing in any form.
- 19) To reduce the chances of injury, make sure to abide by the guidelines in this instruction sheet.

Direct From **Consumer Product Safety Commission Outdoor Home Playground Safety Handbook** Section 4. Select Protective Surfacing:

One of the most important things you can do to reduce the likelihood of serious head injuries is to install shock-absorbing protective surfacing under and around your play equipment. The protective surfacing should be applied to a depth that is suitable for the equipment height in accordance with ASTM F1292. There are different types of surfacing to choose from; whichever product you select, follow these guidelines:

NOTE: Do not install home playground equipment over concrete, asphalt, or any other hard surface. A fall onto a hard surface can result in serious injury to the equipment user. Grass and dirt are not considered protective surfacing because wear and environmental factors can reduce their shock absorbing effectiveness. Carpeting and thin mats are generally not adequate protective surfacing. Ground level equipment -- such as a sandbox, activity wall, playhouse or other equipment that has no elevated play surface -- does not need any protective surfacing.

Loose-Fill Materials

- Maintain a minimum depth of 9 inches of loose-fill materials such as wood mulch/chips, engineered wood fiber (EWF), or shredded/recycled rubber mulch for equipment up to 8 feet high; and 9 inches of sand or pea gravel for equipment up to 5 feet high. NOTE: An initial fill level of 12 inches will compress to about a 9-inch depth of surfacing over time. The surfacing will also compact, displace, and settle, and should be periodically refilled to maintain at least a 9-inch depth.
- Use a minimum of 6 inches of protective surfacing for play equipment less than 4 feet in height. If maintained properly, this should be adequate. (At depths less than 6 inches, the protective material is too easily displaced or compacted.)
- Use containment, such as digging out around the perimeter and/or lining the perimeter with landscape edging. Don't forget to account for water drainage.
- Check and maintain the depth of the loose-fill surfacing material. To maintain the right amount of loose-fill materials, mark the correct level on play equipment support posts. That way you can easily see when to replenish and/or redistribute the surfacing.
- Do not install loose fill surfacing over hard surfaces such as concrete or asphalt.

Page 3/4

Poured-In-Place Surfaces or Pre-Manufactured Rubber Tiles

- You may be interested in using surfacing other than loose-fill materials - like rubber tiles or poured-in-place surfaces.
- Installations of these surfaces generally require a professional and are not "do-it yourself" projects.
- Review surface specifications before purchasing this type of surfacing. Ask the installer/manufacturer for a report showing that the product has been tested to the following safety standard: ASTM F1292 Standard Specification for Impact Attenuation of Surfacing Materials within the Use Zone of Playground Equipment. This report should show the specific height for which the surface is intended to protect against serious head injury. This height should be equal to or greater than the fall height - vertical distance between a designated play surface (elevated surface for standing, sitting, or climbing) and the protective surfacing below - of your play equipment.
- Check the protective surfacing frequently for wear.

Placement

Proper placement and maintenance of protective surfacing is essential. Be sure to:

- Extend surfacing at least 6 feet from the equipment in all directions.
- For to-fro swings, extend protective surfacing in front of and behind the swing to a distance equal to twice the height of the top bar from which the swing is suspended.
- For tire swings, extend surfacing in a circle whose radius is equal to the height of the suspending chain or rope, plus 6 feet in all directions.

This instruction sheet is an integral part of the product. Please retain it for your record.

SUNNYWOOD WILL NOT BE LIABLE FOR ANY DAMAGES/INJURIES OF ANY KIND ARISING FROM THE USE OF, OR INABILITY TO USE THIS ITEM WHETHER DISTRIBUTED THROUGH IT OR ANY AFFILIATES, INCLUDING BUT NOT LIMITED TO DIRECT, INDIRECT, INCIDENTAL, PUNITIVE, AND CONSEQUENTIAL DAMAGES. THE USER ASSUMES FULL RESPONSIBILITIES FOR ANY OR ALL DAMAGES/INJURIES OF ANY KIND RECEIVED DUE TO MISUSE, WRONG HANDLING AND/OR IMPROPER INSTALLATION/ASSEMBLY.

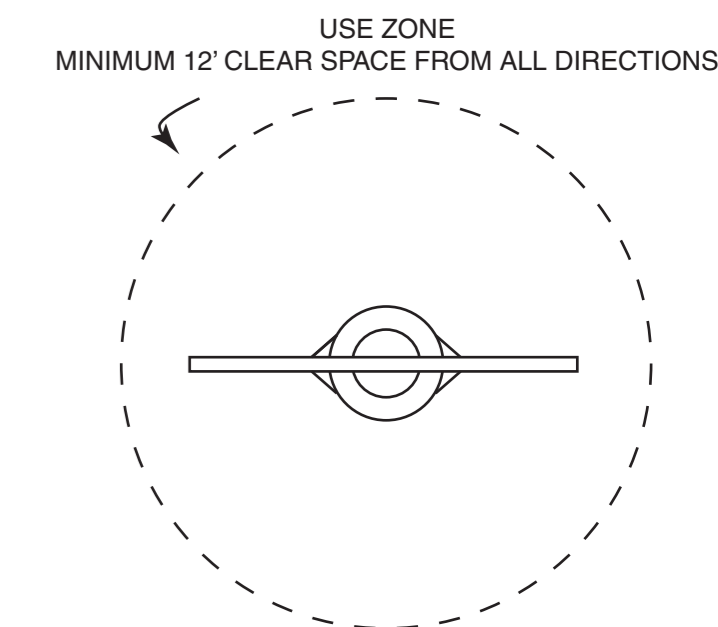
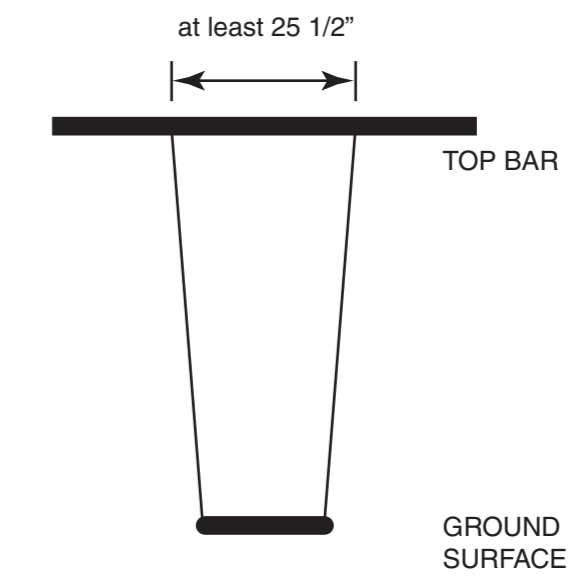

⚠ WARNING: CHOKING HAZARD

Unassembled parts may be a choking hazard to children 3 years and younger.

⚠ CAUTION:

Adult assembly required. Hardware contains small screws with sharp points. Keep unassembled parts out of the reach of small children. Parts of product can present dangers if it is not correctly assembled.

MADE IN CHINA

© 2016 Sunnywood Inc. All rights reserved.

www.sunnywood.net

Style No. 4416RD

Page 4/4